

Spring Cylinder Linear Actuator



Linear Actuator

General arrangement

Mascot spring cylinder linear actuator is a powerful, high-performance pneumatic actuator, which provides positive throttling or on-off operation to pneumatic control valves. Uniquely designed positioner with multiple sized cylinders supply pressures up to 150 psi, making very high thrusts available in a relatively compact unit.

The Mascot spring cylinder linear actuator is fully field reversible for air-to-open or air-to-close action without additional parts; a spring provides reliable fail-safe operation. Air is supplied to both the sides of the piston by the positioner providing very stiff and precise movement alongwith very high frequency response.

Figure 1: Spring Cylinder Linear Actuator

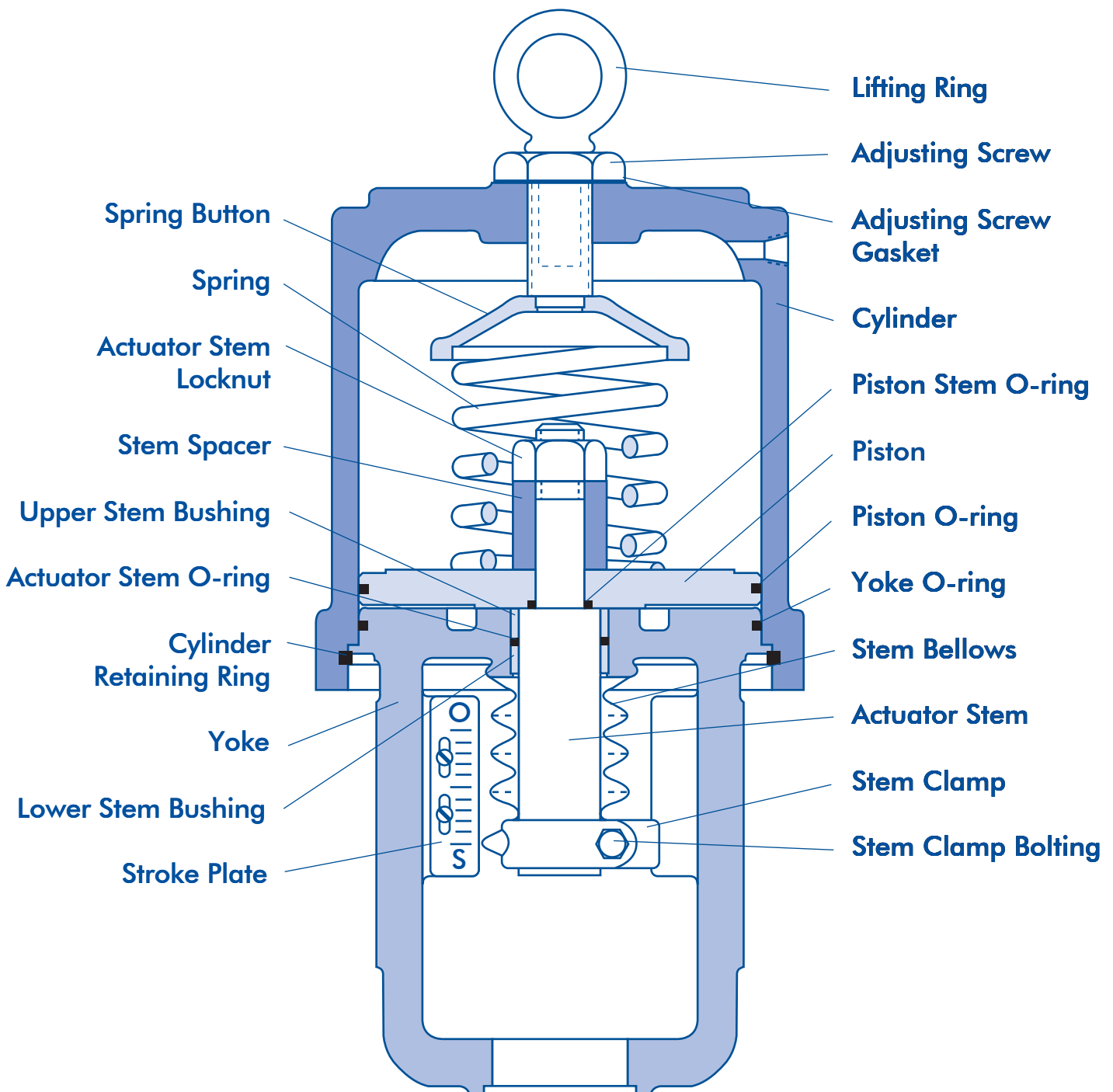

Linear Actuator

Features and Advantages

Following are the Salient features and advantages of the Mascot spring cylinder linear actuator:

Salient features	Advantages
Higher thrust	<ul style="list-style-type: none"> Operating pressure of 150 psi (10.3 Bar) permitting substantially higher thrust capabilities than diaphragm actuators. Tighter valve shutoff due to higher thrust.
High frequency	<ul style="list-style-type: none"> Responds quickly to signal changes because of double acting configuration.
Lightweight and Compact	<ul style="list-style-type: none"> Substantially lighter and more compact than comparable linear diaphragm actuators. Offers ease of maintenance.
Wild choice	<ul style="list-style-type: none"> Usual actuator sizes 25, 50 and 100 and a few more that can handle thrust requirements for over 95 percent of valve sizes. For special applications, larger sizes up through size 600 are available.
Least number of parts	<ul style="list-style-type: none"> 33% less parts than diaphragm actuators Cost of wear parts is 10% then for diaphragms, actuators allowing low inventory and maintenance.
Excellent positioning accuracy	<ul style="list-style-type: none"> Powerful pneumatic stiffness allows a high pressure drop without plug slamming is possible due to air volume between the piston and the bottom of the cylinder. For stiff and precise actuator operation, supply pressure is sent to both sides of the piston.
Field reversible	<ul style="list-style-type: none"> Easily reversible failure mode without additional parts leading to reduced inventory costs.
No need of pressure regulators	<ul style="list-style-type: none"> Easy handling of air supplies up to 150 psi (10.3 bar) without a pressure regulator and can be operated with as little as 30 psi (2.1 Bar).*
Spring is fail-safe	<ul style="list-style-type: none"> Fail-safe operation is provided by internal spring in the event of air system failure. Universal spring bench set is not needed.
Stiff operation	<ul style="list-style-type: none"> Supply pressure is sent to both sides of piston for stiff actuator operation.
Sturdy components	<ul style="list-style-type: none"> Minimal maintenance is needed as there is no diaphragm, therefore no rupture.
Easy maintenance	<ul style="list-style-type: none"> The spring cylinder actuator only needs the removal of two parts to access the internal parts.
Low consumption of air	<ul style="list-style-type: none"> As compared to diaphragm actuators, cylinder design uses less supply of air.
Strokes are longer	<ul style="list-style-type: none"> In comparison to a 3/4 inch (19mm) stroke on a comparable linear diaphragm actuator Size 25 spring cylinder linear actuator has a 1 1/2 - inch (38mm) stroke. Stroke lengths available up to 24 inches.
High-level positional stiffness	<ul style="list-style-type: none"> Small air volume between the piston and the bottom of the cylinder provides powerful pneumatic stiffness – allowing high pressure, flow over the plug operation without plug slamming.

* Limited operating pressure on some sizes because of valve sizes.

Linear Actuator

Actuator rigidity

Control valve operates with normally fluctuating flow. As this might vary a force. It becomes necessary for the control valve to remain in the same position as signaled by the controller. To achieve required position, the valve depends on actuator stiffness. Actuator stiffness is defined as an ability of an actuator to withstand dynamic fluid forces acting on the valve trim. For stiff and precise actuator operation, air pressure is supplied to both sides of the piston, making the stiffness of the Mascot spring cylinder greater than a valve with an actuator having diaphragm.

The stiffness, spring rate is equal to :

$$K = \frac{kPA^2}{v}$$

- Where:
- K = spring rate
 - k = ratio of specific heat
 - P = supply pressure
 - A² = piston area (in ²)
 - v = cylinder volume under piston

A 25 square-inch cylinder actuator at mid stroke (typical for a 2" valve) with a supply air pressure of 100 psi (6.9 Bar) and a 3/4" (19mm) stroke will give the spring rate of 9333 lbs. per inch at mid-stroke. See figure 2.

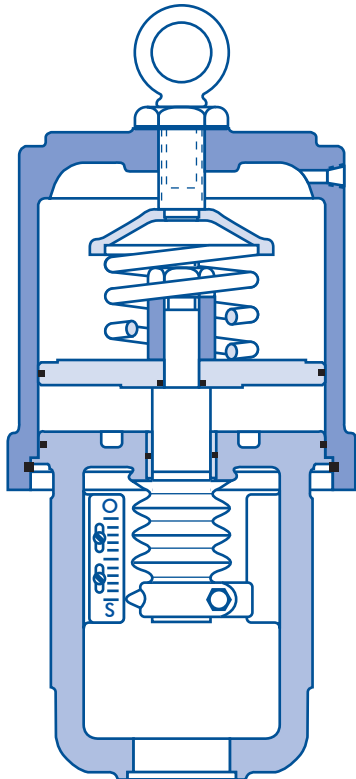

Figure 2: Cylinder Actuator at Mid-stroke

The inherent property of this design is that as the volume under the piston becomes smaller, the stiffness factor becomes larger in a Mascot cylinder actuator. The equivalent diaphragm actuator (46 square-inches) on the same valve with a 3-15 psi (0-1 Bar) signal has a spring rate of only 920 lbs. per inch (161 kN/m) at mid-stroke. The spring rate for a diaphragm actuator remains the same, regardless of diaphragm position. When a valve with a diaphragm actuator is operated close to the seat with flow over the plug, sudden changes in the dynamic force can cause the valve to slam shut. Because of this low-stiffness factor, diaphragm operated valves are installed with the flow under the plug.

As the valve plug approaches the seat, the stiffness of the Mascot spring cylinder actuator actually increases. The chances of the plug slamming into the seat are reduced. e.g. A well designed actuator, with 100 Psi (6.9 bar) supply air pressure and the plug 1/8" (3 mm) away from a seat, the piston is 3/16" (5 mm) from the bottom of the cylinder. At this point, the actuator generates a stiffness of 18,667 lbs. per inch (3269 kN/m). See figure 3.

Thus, a spring cylinder actuated control valve may be operated with the flow either over the plug or under the plug, and still maintain the precise, throttling control required by today's processes. This advantage allows the flow to assist the actuator spring in obtaining the required failure position and increases the ability of the valve for a tight shut off.

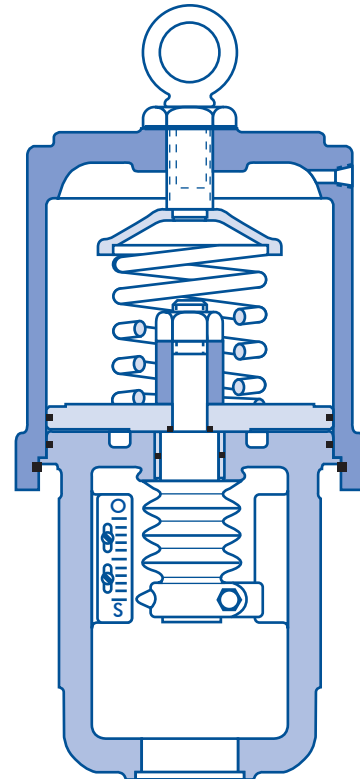

Figure 3: Cylinder Actuator with High Stiffness/Spring Rate

Linear Actuator

Actuator performance

Thrust Producing Capability

As compared to the diaphragm actuators, Mascot linear spring cylinder actuators produce substantially higher thrust. The cylinder operates with supply pressures up to 150 psi (10.3 Bar). Throttling diaphragm actuators are limited to 40-60 psi (2.8-4.1 Bar), thereby reducing their thrust producing capability. Higher actuator air supply, coupled with high-pressure air on both sides of the actuator piston, provide exceptional stiffness for precise throttling control. Mascot cylinder actuator stiffness is sufficient to control high pressure drops and allows the plug to throttle near the seat.

Sensitivity and Speed

Fast stroking speeds are produced because of higher air volume handling capabilities of the positioner, coupled with relatively low cylinder volumes. When approaching the final plug position, high operating speed is achieved with virtually no overshoot. Static sensitivity of the unit is excellent. e.g. As little as 0.008 psi (0.0006 Bar) is required to move the stem 0.0005 inches (0.0127 mm) (the minimum detectable movement in the tests conducted) on a size 25 actuator. To reverse the stem motion, signal change of only 0.01 psi (0.007 Bar) is needed. Presented in the table 1 are typical stroking times. Increased stroking speeds are available with Mascot flow booster valves.

Table I: Typical Actuator Stroking Times

Actuator Size	Time (Seconds) For Maximum Stroke*		Stroke (inches)
	1/4" Tubing	3/8" Tubing	
25	1.2	1.0	1.5
50	3.5	3.1	3
100	9.6	8.6	4
200	20.8	18.4	4
300	31.3	27.7	4

Actuation pressure: 60 psi (4.1 Bar)

* Stroking time only (does not include time from receipt of signal and beginning of stem motion).

Frequency Response

Extremely high frequency response is available with Mascot cylinder actuator than comparable diaphragm actuator units. Such response is achieved through a double-acting configuration that uses pressure on both sides of the piston.

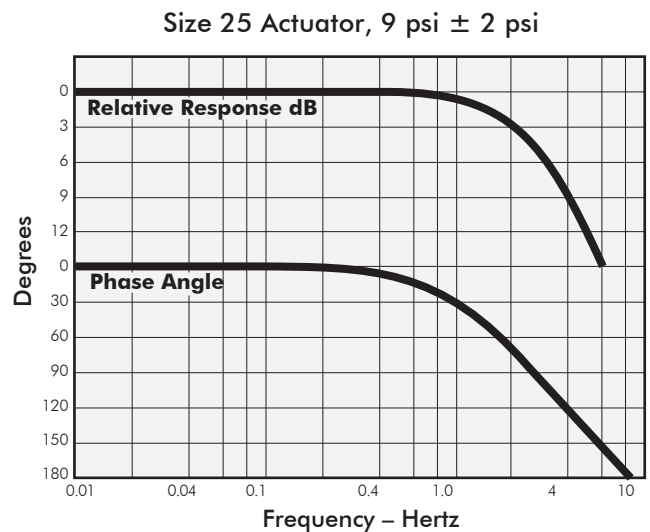

Figure 4: Frequency Response

Hysteresis and Linearity

Ability to respond linearly to signal changes from the controller and to provide uniform response unaffected by decreasing or increasing pressures is an important characteristic of any actuator. Tests prove the linearity of the cylinder actuator to be within $\pm 1.0\%$. The same tests showed that the difference in valve position for a given instrument signal, regardless of the required direction of change in the pistons position, was extremely small (refer to Table VII Positioner Performance on page 11).

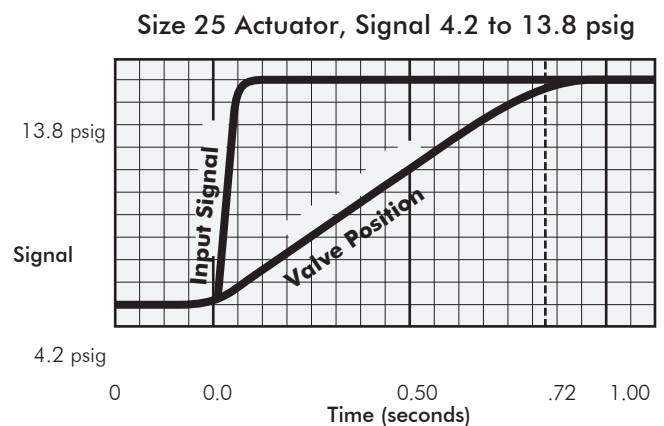

Figure 5: Step Test

Linear Actuator

Construction

Reversible Air Action

Providing either air-to-open (air-to-retract) or air-to-close (air-to-extend) action with easy reversal in the field is a function of standard cylinder actuators. The spring is installed on the upper side of the piston. For air-to-close action, the spacer and spring are installed on the underside of the piston with the spring button stored on top of the piston.

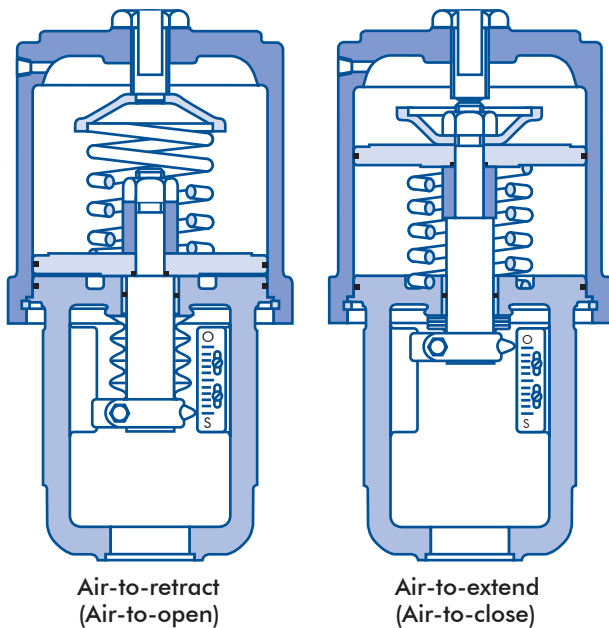

Figure 6: Spring Cylinder Air Action

Sizes

Three standard sizes: 25, 50 and 100 square-inches (nominal piston area) and five oversized actuator sizes: 200, 300, 400, 500 and 600 square-inch are available with Spring cylinder linear actuators. A tandem of double piston configuration is possible with 400 and 600 sizes.

Materials of construction

Corrosion resistant anodized aluminum is used in the cylinder and piston. The tough ductile iron yoke withstands the impact. Exposed actuator stem is made up of stainless steel, guided by oilite bronze bushings. The yoke, cylinder, clamps and other exposed parts can be supplied in stainless steel. Clamps, bolts, nuts and yokes made in stainless steel are available from regular stock.

Table II: Materials of Construction

Part	Material
Yoke	Phosphated, painted ductile iron
Yoke clamp	Stainless steel
Yoke clamp bolts	Zinc plated steel
Stem clamp*	Phosphated, painted ductile iron
Stem clamp nut and bolt	Zinc plated steel
Cylinder retaining ring	Zinc plated steel
Actuator stem	416 stainless steel
Stem spacer	Aluminum
Actuator stem	lock nut Zinc plated steel
O-rings	Buna-N
Spring	Alloy steel
Spring button	Painted steel
Adjusting screw	Zinc plated steel
Piston	Anodized aluminum
Cylinder	Painted anodized aluminum

*Denotes stainless steel material on 25 and 50 sq.in.

Table IV: Mascot Cylinder Data

Cylinder Size	Cylinder Bore Dia. (in.)	Upper Cylinder Area (sq.in.)	Lower Cylinder Area (sq.in.)	Stem Diameter (in.)	Stem Area (sq.in.)	Maximum Volume Over Piston (cu.in.)
25	5.50	23.76	22.97	1.00	0.79	100
50*	7.75	47.17	46.39	1.00	0.79	331
50	7.75	47.17	45.67	1.38	1.50	331
100*	11.00	95.03	93.26	1.50	1.77	1031
100	11.00	95.03	91.06	2.25	3.98	1031
200	15.50	188.7	184.7	2.25	3.98	2087
300	19.50	298.6	292.7	2.75	5.94	3733
400**	15.50	371.5	365.5	2.75	5.94	3033
500	25.25	500.7	494.8	2.75	5.94	5519
600**	19.50	590.2	583.1	3.00	7.07	5661

*Used as oversized actuators in place of the next smaller actuator

**Tandem, double piston configuration

Table III: Actuator Specifications

Type	Cylinder with positive spring action
Sizes	25, 50, 100, 200, 300, 400, 500 and 600 sq. in.
Spring Designs	Single (std.) and dual
Action	Field reversible: Air-to-open, Air-to-close
Operating pressure	Up to 150 psi (10.3 Bar)
Temperature range	-40° to 350° F* (-40° to 177°C*)

* Ambient temperatures greater than 180° F (82° C) require Viton O-rings. Ambient temperatures below -40° F (-40° C) require fluorosilicone O-rings.

Linear Actuator

Components of the actuator

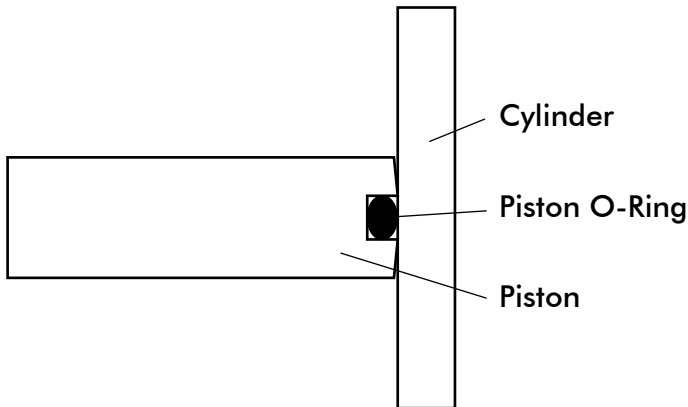

Figure 7: Piston Seal

A Buna-N O-ring seals the piston. The smooth finish of cylinder bore ensures long service life. Dow corning 55M is used to lubricate the cylinder walls. This lubricant does not dissolve in water or oils that may be present in the air supply, and is effective over a wide temperature range from -50° to 350° F (-46° to 177° C). Where ambient temperatures are expected to exceed 120° F (49° C), a special Viton O-ring can be supplied. Tests have demonstrated service life in excess of five million strokes with zero or negligible leakage. In continuous service for many years, Piston O-rings used in these actuators have proven successful.

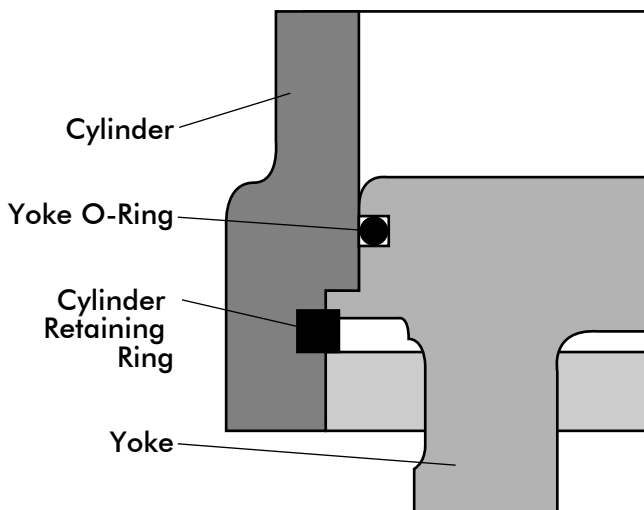

Figure 8: Cylinder to Yoke Attachment

A solid square retaining ring attaches the cylinder to the yoke. Removal is easy with the aid of two screw drivers. (Please refer the Mascot Installation, Operation and Maintenance Instructions for correct disassembly procedures). A static O-ring is located at the cylinder bore and also at the actuator.

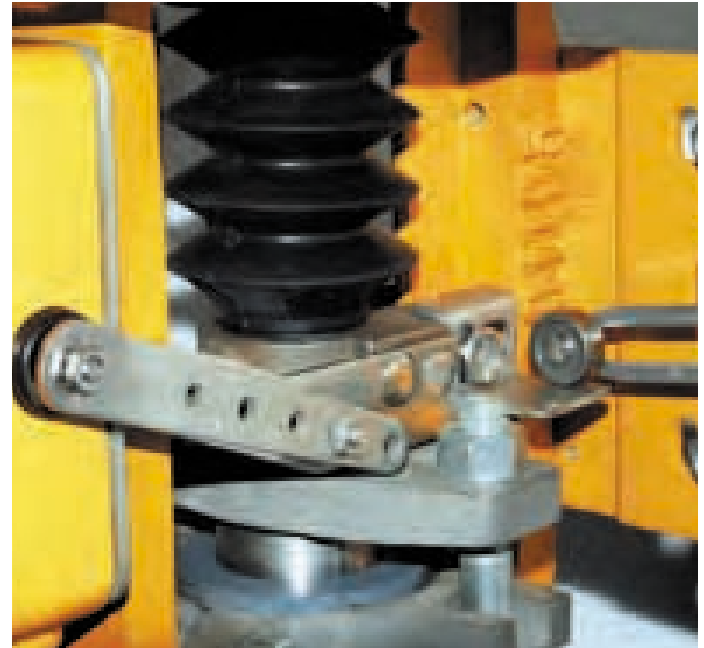

Figure 9: Stem Clamp

A split steel clamp locks the actuator stem to the plug stem. A split actuator stem permits this clamping action. Both stems have standard wrench flats to simplify adjustment of plug stem/actuator stem length. Feedback linkage attached to the stem clamp is for transmitting the position of the actuator to the positioner. In conjunction with the stroke plate, a pointer is used fixed to one web of the yoke to indicate the actuator stroke. The clamp and stem are prevented from rotating by the other web.



Figure 10: Lifting Ring

Size 25 and 50 actuators are furnished with a lifting ring that is screwed into the adjusting screw to facilitate handling of the actuator assembly. Size 100 and larger actuators will accept a standard eyebolt.

Linear Actuator

Springs data

Table V: Cylinder Actuator Spring Data

Cylinder	Stroke (inches)	Spring Design	Rate		Air-to-open (Air-to-retract)				Air-to-close (Air-to-extend)			
					lb/in	(N/m)	Spring Ext. lbs	Spring Ref. N	Spring Ref. lbs	Spring Ext. N	Spring Ref. lbs	Spring Ext. N
25	3/4	STD	180	31523	281	1250	416	1850	450	2002	315	1401
	1	STD	180	31523	236	1050	416	1850	450	2002	270	1201
	1 1/2	STD	180	31523	146	649	416	1850	450	2002	180	801
	3/4	DUAL	447	78282	629	2798	964	4288				
	1	DUAL	447	78282	629	2798	1075	4782				
50	1 1/2	DUAL	447	78282	405	1802	1075	4782				
	1 1/2	STD	164	28721	369	1641	615	2736	656	2918	410	1824
	2	STD	164	28721	287	1277	615	2736	656	2918	328	1459
	2 1/2	STD	164	28721	205	912	615	2736	656	2918	246	1094
	3	STD	164	28721	123	547	615	2736	656	2918	164	730
	1 1/2	DUAL	447	78282	1194	5311	1864	8291				
	2	DUAL	447	78282	970	4315	1864	8291				
100 thru 600	2 1/2	DUAL	447	78282	747	3323	1864	8291				
	3	DUAL	447	78282	523	2326	1864	8291				
	2	STD	300	52538	1125	5004	1725	7673	1725	7673	1125	5004
	2 1/2	STD	300	52538	975	4337	1725	7673	1725	7673	975	4337
	3	STD	300	52538	825	3670	1725	7673	1725	7673	825	3670
	4	STD	300	52538	525	2335	1725	7673	1725	7673	525	2335
	2	HEAVY*	535	93693	2098	9332	3168	14092				
	2 1/2	HEAVY*	535	93693	1831	8145	3168	14092				
	3	HEAVY*	535	93693	1563	6953	3168	14092				
	4	HEAVY*	535	93693	1028	4573	3168	14092				
600	2	DUAL	885	154987	3471	15440	5241	23313				
	2 1/2	DUAL	885	154987	3029	13474	5241	23313				
	3	DUAL	885	154987	2586	11503	5241	23313				
	4	DUAL	885	154987	1701	7566	5241	23313				

* Heavy spring includes outer spring of dual spring set.

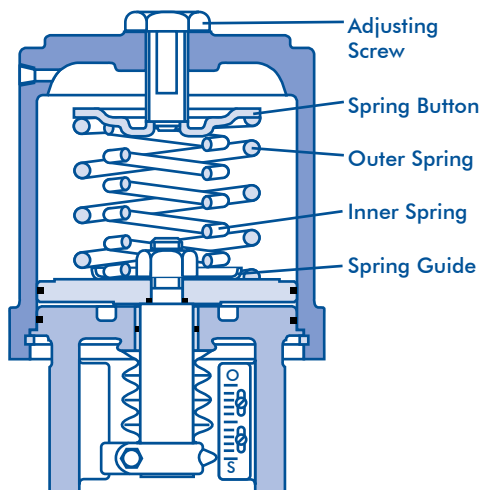

Figure 11: Dual Spring Actuator

The unique four-way, double acting design in the Mascot cylinder actuators does not require springs for positioning. The spring serves only as a fail-safe device. It should be noted that although valve flow direction usually assists the actuator on loss of air, normally the spring is designed to achieve the fail position independently. Proper sizing of the cylinder spring requires an understanding of the specific spring force listed in the table above.

Dual Spring Actuator Construction

For heavy duty service in the air-o-retract (air-to-open) configuration, Dual springs are available. Only five additional parts: a new actuator stem, a spring button, the inner spring, outer spring and a spring guide are needed for retrofitting a standard cylinder actuator to dual springs. On the other hand, valve equipped with dual spring actuators are not field reversible and require a minimum of 60 psi (4.1 Bar) supply

Linear Actuator

Valve Positioners

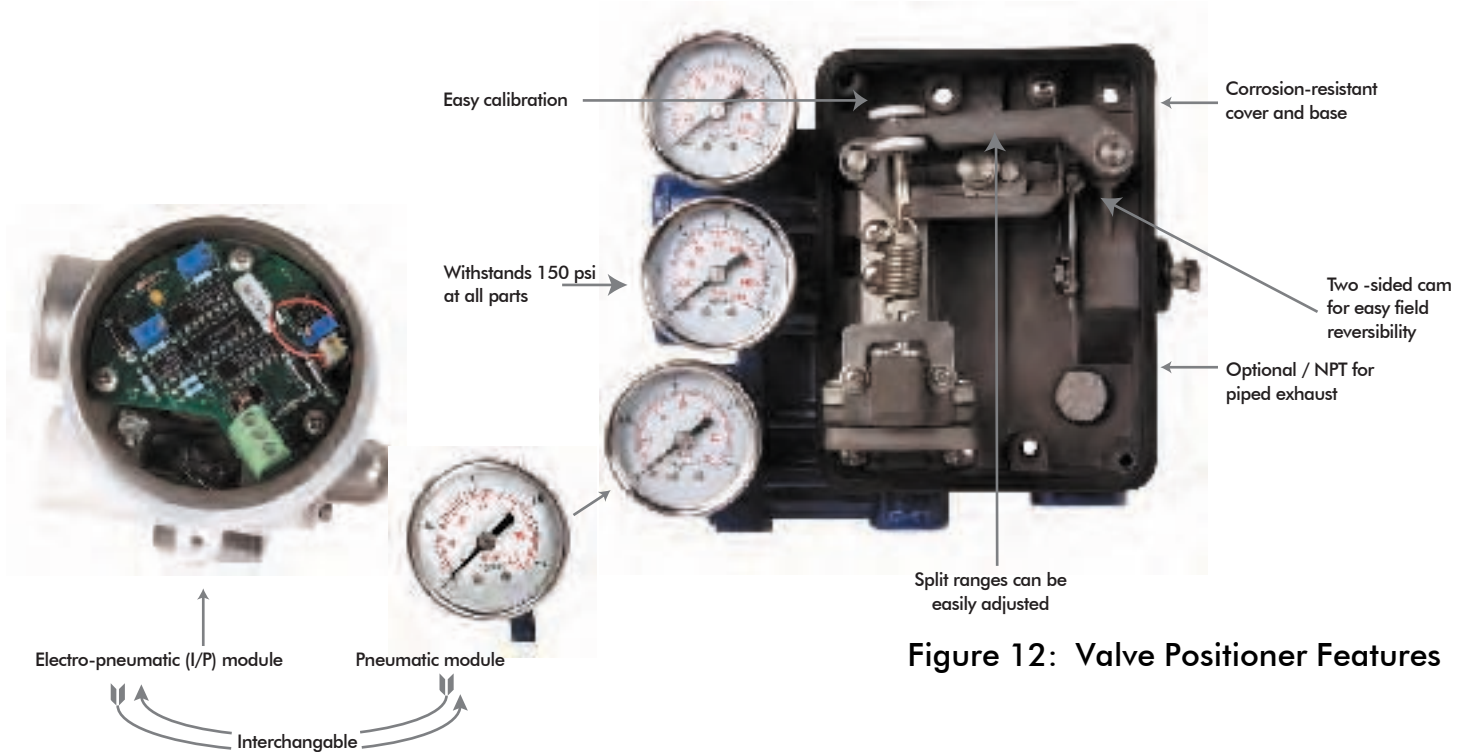

Figure 12: Valve Positioner Features

Valve positioners are primarily utilized by Mascot. A pneumatic module for air control signals, or an electro-pneumatic (I/P) module for milliamp electrical control signals is offered with Mascot valve positioner. Valve positioners are single or double-acting, force-balanced instruments that provide fast, sensitive and accurate positioning of cylinder and diaphragm actuators. These positioners being compact, field reversible, are designed for high performance and are reliable because of the rugged built.

Features

- **P/P or I/P Signal Convertible** – Easy accomplishment of field conversion from one control signal to another by replacing one module with another
- **Corrosion Resistant** – Epoxy powder painted on cover and base assembly and continuously purged from the inside with instrument air making corrosion resistant internal section. Internal working parts are constructed from 300 series stainless steel, anodized aluminum or Buna-N.
- **Shock and Vibration Resistant** – the make and design of valve positioners is such that they have high natural frequency coupled with pneumatic damping. It is unaffected by vibration, acceleration up to 2 G's, and frequencies to 500 Hz.
- **For Single or Double-acting Actuators** – The valve positioner is versatile usable with either single or double acting actuators.
- **Standard Mounting** – Valve positioners use the standard mounting. By changing the cams and follower arms, the same positioner can be used on both linear and rotary actuators. This results in fewer required spare parts.

- **Easily Field Reversed** – A reversal of action in the field is achieved by simply turning the cam over, reversing the anti-backlash spring and changing the output tubing.
- **Insensitive to Mounting Position** – Positioners can be mounted in any orientation.
- **Simple Calibration** – Easy calibration as there is minimal interaction between zero and span. For protection and to discourage tampering, positioner adjustments are totally enclosed.
- **Split-Range Service** – Standard signal ranges are 4 - 20 mA for the electro-pneumatic (I/P) module and 3-15 psi (0-1 Bar) for the pneumatic (P/P) model. Optional ranges are 10-50 mA and 6-30 psi (0.4-2.1 Bar), respectively. All models can be calibrated for a 2 or 3-way split range.
- **Simplified Maintenance** – Ease in maintenance because of positioners simplicity, modular design and a few parts.
- **Regulator not needed** – Designed to withstand 150 psi (10.3 bar) at all parts, the valve positioners are insensitive to supply pressure fluctuations.
- **Low Air Consumption** – Steady state air consumption is .25 SCFM @ 60 psi (4.1 Bar) supply.
- **Changeable Flow Characteristics** – Easily changed cam provides characterized flow feedback.
- **High Air Flow Gain Model** – Standard on 200 square inch actuators and above, optional on others.
- **Output Gauge Helps Monitor Unit:** – Permits easy verification of transducer and positioner calibration as it indicates transducer output to the positioner.

Linear Actuator

Valve Positioner Operation

Figure 13 shows a valve positioner. The valve positioner is a force-balanced instrument, with pneumatic module installed on a double-acting actuator for air to open action. Positioning is based on a balance of two forces; one proportional to the instrument signal and the other proportional to the stem position.

A downward force is activated as the signal pressure acts upon the diaphragms in the instrument signal capsule, through the follower arm and cam, the motion of the actuator stem is transmitted to the top end of the feedback spring resulting in the varying of tension in feedback spring as stem position changes.

The system will be in equilibrium and stem will be in the position called for by the instrument signal when these opposing forces balance exactly. The balance will move up or down and by means of the spool valve, will change the output pressures and flow rate if these opposing forces are not in balance. This will lead to the piston to moving until the tension on the feedback spring opposes exactly the instrument signal pressure.

The detailed sequence of positioner operations are as follows: An increase in the instrument signal forces

the instrument signal capsule and balance beam downward. This motion of the balance beam also pulls the pilot valve spool downward from its equilibrium position. This opens the pilot valve ports, supplying air to port 1 and exhausting air from port 2. This causes the actuator piston upward.

Proportionally to the valve position, to counter the force generated by the instrument signal capsule, the piston continues to stroke upwards until force in the feedback spring increases sufficiently. At this point the balance beam and spool begin to return to equilibrium position. As the valve spool ports start to close, the air flow rate to the actuator is decreased.

The feedback spring tension force will equal the force generated in the instrument signal capsule after the piston has reached the required position. The balance beam and instrument signal capsule will remain in their equilibrium positions with no air flowing to the actuator until a change in the instrument signal is made.

A proportional downward movement of the actuator piston and stem is affected by a decrease in the instrument signal which reverses the described actions.

Figure 13: Positioner Schematic for Air-to-Open (Retract)

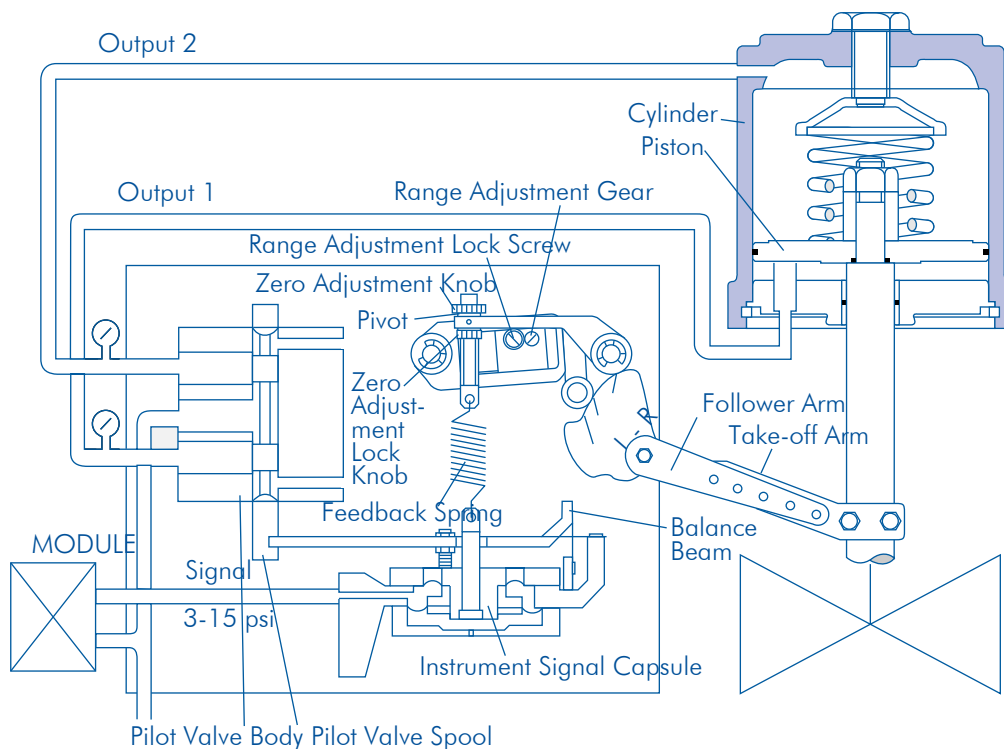

Linear Actuator

Valve Positioner Specifications

Table VI: Valve Positioner Specifications

Specification	Pneumatic Module
Input signal range:	3-15 psi (0-1 Bar), 2 or 3-way split range; 6-30 (0.4-2.1 Bar) psi, 2 or 3 and 4-way
Supply pressure	30 psi to 150 psi (2.1 to 10.3 Bar)
Ambient temperature limits	Standard model: -20° to +185° F (-30° to 85° C) Ext. temp. model: -50° to +250° F (-46° to 121° C)
Connections	Supply, instrument and output: 1/4 -inch NPT; Gauges: 1/8 -inch NPT
Standard materials	Stainless steel, anodized aluminum, nickel-plated steel, epoxy powder-painted steel and Buna-N
Net weight	3 lbs. (1.4 kg)

Table VII: Valve Positioner Performance*

Valve Positioner Performance	Pneumatic Module
Independent Linearity – Maximum deviation from a best fit straight line	±1.0%F.S.
Hysteresis – Maximum position error for the same value of input when approached from opposite ends of the scale.	0.5% F.S.
Repeatability – Maximum variation in position for the same value of input when approached from the same direction.	0.2% F.S.
Response Level – Maximum change in input required to cause a change in valve stem position in one direction.	0.2% F.S.
Dead Band – Maximum change in input required to cause a reversal in valve stem movement.	0.3% F.S.
Resolution – Smallest possible change in valve stem position.	.1% F.S.
Steady State Air Consumption @ 60 psi (4.1 Bar)	.25 SCFM
Supply Pressure Effect – Position change for a 10 psi (0.7 Bar) supply pressure change.	.05% F.S.
“Open-loop” Gain – Ratio of cylinder pressure unbalance to instrument pressure change with locked stem.	300:1 @60 psi
Maximum Flow Capacity @ 60 psi (4.1 Bar)	11 SCFM
Frequency Response – (With sinusoidal input of ±5% F.S. centered about 50% F.S.)	-6 dB Frequency Phase Angle at -6dB
Stroking Speed –	Closed to open - Open to closed -
	.8 Hz -71°
	2.3 in/sec. 1.3 in/sec.

*Data is based on tests of the Valve positioner mounted on a double-acting cylinder actuator having a piston area of 25 square inches with a valve stroke of 1.5 inches (38mm) and 60 psi (4.1 Bar) supply pressure. Instrument signal was 3-15 psi (0-1 Bar) with pneumatic module

Linear Actuator

Side-mounted continuously connected handwheels

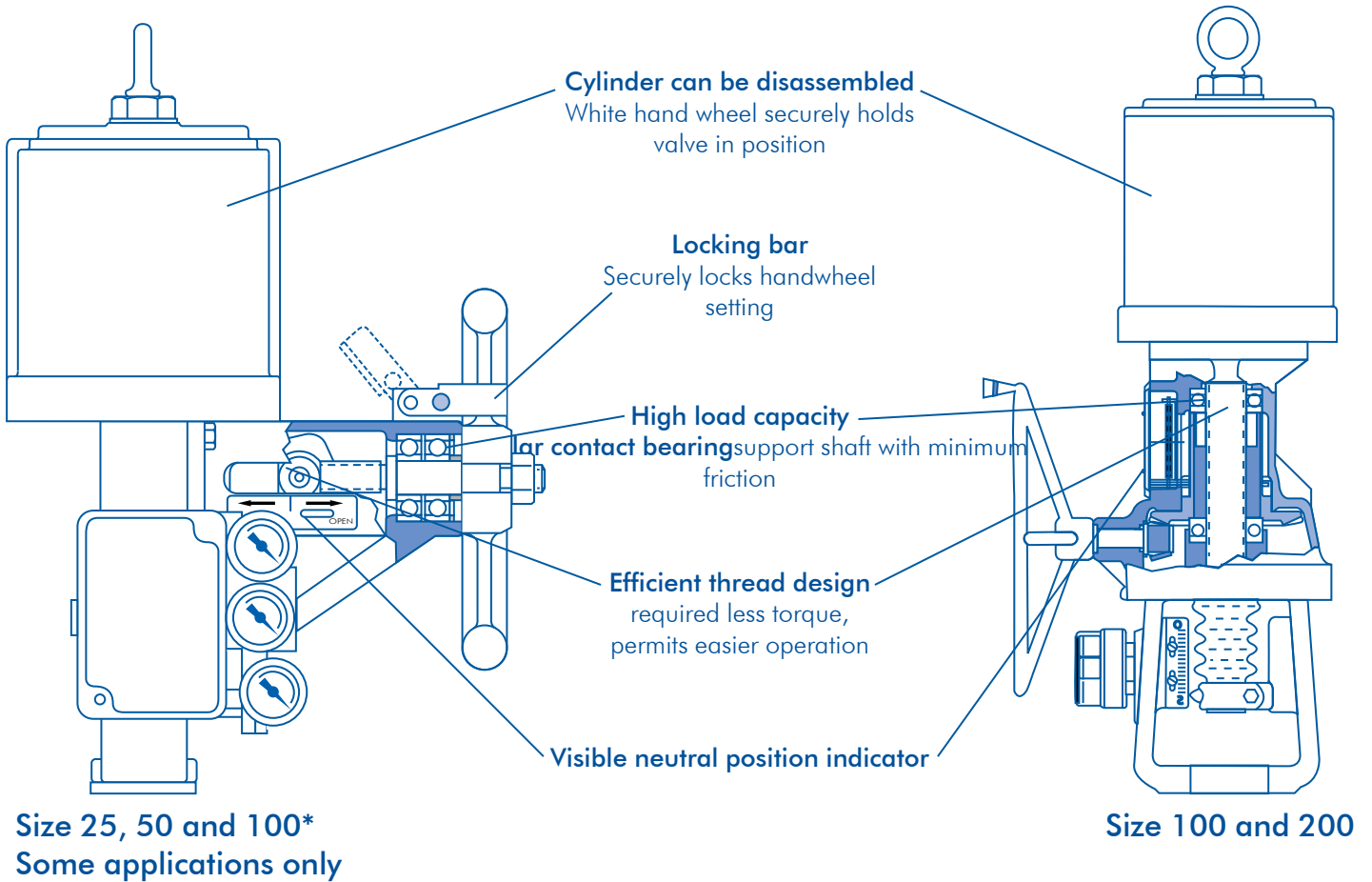

Mascot's side-mounted handwheel is a continuously connected, declutchable design which permits manual operation of linear actuators. This is standard for valves up to and including 4" strokes. It is especially convenient during start-up, in emergencies, or due to air failure. Its efficient design utilizes heavy-duty, anti-friction bearings that allow high thrust with low torque on the handwheel. The side-mounted handwheel provides the mechanical advantage needed for manual operation. Therefore, the handwheel provides an effective means to overcome the fluid forces or friction within the valve during manual operation.

Other advantages characterize side-mounted design:

1. The pneumatic spring cylinder can be disassembled while the handwheel holds the valve in position on fail-open valves. On fail-closed valves, the valve must be closed.

2. Convenient access allows operator to turn the handwheel easily in a more natural position.
3. Easy adaptation to a chain-driven mechanism is possible.

Due to the continuously-connected design, the handwheel can act as a high or low-limit stop. By effectively isolating the actuator stem from the actuator, the continuously-connected handwheel permits positioner and actuator maintenance without interruption of service.

The side-mounted handwheel features a highly visible, neutral-position indicator and comes standard with a locking bar.

A three-way bypass valve is installed in the positioner supply line to shut off the air supply or neutralize the pressure across the piston when operating the valve manually.

Linear Actuator

Side-mounted continuously connected handwheels

**Table VIII:
Standard Materials of Construction
Size 25, 50, 100 and 200**

Part	Material
Yoke	Ductile iron
Actuator stem pin	Stainless steel (hardened)
Crank lever	4130 alloy steel (heat treated)
Crank pivot pin	416 stainless steel
Drive nut	Aluminum bronze*
Handwheel shaft (ACME screw)	416 stainless steel*
Handwheel	Aluminum/Tubular Steel
Housing	Ductile iron

*Coated with electro film lubricant



Table IX: Side-mounted Continuously Connected Handwheel Specifications

Act. Size	Spud	HW Operator Size	HW Diameter		Turns per		Force Amplification Factor	Maximum Stroke		Weight	
			in	mm	in	mm		in	mm	lb	kg
25	2.00	25	9	230	5.3	.21	44:1	1.5	38	39	18
50	2.00	25	12	305	5.3	.21	58:1	3.0	76	85	39
50	2.62	50	12	305	6.7	.26	63:1	3.0	76	96	44
100 ⁽¹⁾	2.62	50	18	455	6.7	.26	95:1	4.0	102	198	90
100	2.88-4.75	100/200	24	610	8.0	.31	126:1	4.0	102	290	132
200	2.88-4.75	100/200	24	610	8.0	.31	126:1	4.0	102	395	179

Table X: Top-mounted Continuously Connected Handwheel Specifications

100	2.62-4.75	100/200	18	455	12	305	128:1	6.0/8.0	152/203	285	129
200	2.62-4.75	100/200	18	455	12	305	128:1	6.0/8.0	152/203	400	181

(1) 100 psi (6.89 Bar) maximum supply pressure when 50-inch HW Operator is used on a 100-inch actuator

Example: if you apply 50 lb (222 N) rim pull on the 12-inch (305-mm) handwheel of a 50-inch HW operator, then the operator output will be: 50 lb (222 N) rim pull x 63 = 3150 lb (14011 N) output thrust.

Linear Actuator

Top-mounted Handwheels

Two types are available: Continuously connected and push-only. Top-mounted handwheels can be mounted on size 100 and large actuators.

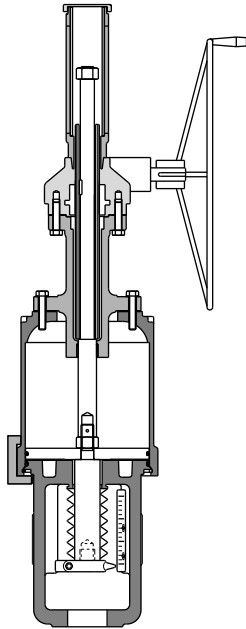

Figure 15:
Continuously-Connected Handwheel

Being highly versatile, they can be used to retract or extend the stem and act as either a high or low-limit stop. A Simplicity of the design makes easy placing of wheel in the neutral position for automatic operation.

A precision-made bevel gear sealed in a weather proof housing is used in the handwheels to maximize performance. High-thrust output can be achieved with low torque input on the hand wheel. For specific applications, consult the factory. In operation, the handwheel consult the factory on capacities for specific applications.

In operation, the handwheel is turned counterclockwise to move the handwheel screw against the stem locknut, retracting the stem. Moving the handwheel clockwise turns the handwheel screw down against the shoulder on the stem, forcing the stem to extend. Returning the handwheel screw to the neutral position (top of the screw even with a neutral line as seen through the transparent cap liner) permits operation of the actuator without interference from the handwheel. Adjusting the handwheel screw to a position other than neutral provides a limit stop to limit travel in either direction.

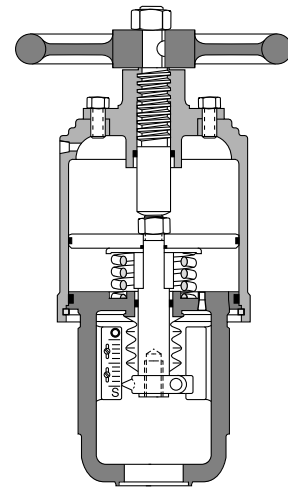

Figure 16: Push-only Handwheel

Turning the handwheel clockwise drives the handwheel stem down to extend the actuator stem. This handwheel can be used to limit upward travel.

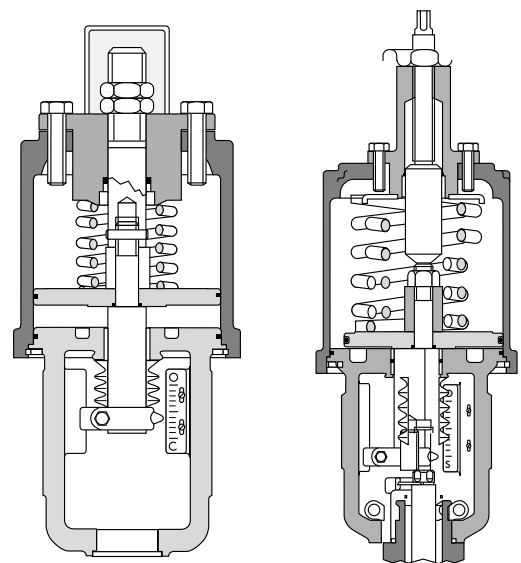

Figure 17: Actuator Limit Stops

Simple actuator stops are available to limit either opening or closing of the valve. Handwheels are not provided, and locknuts are included to maintain precise setting of the selected limit stop position.

Linear Actuator

Lever & manual handwheel actuators

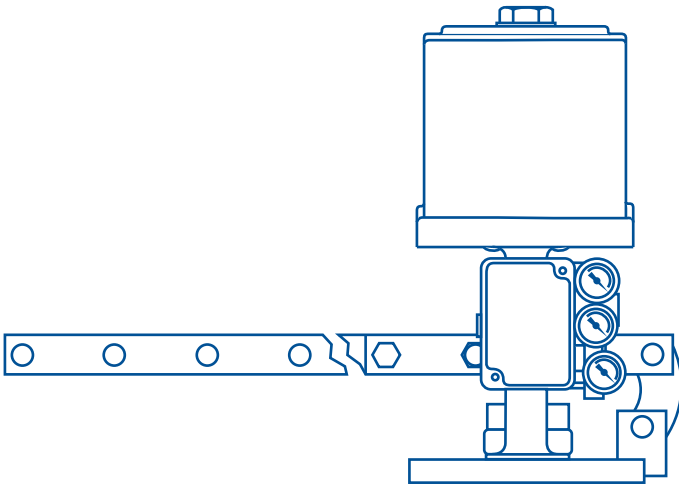

Figure 18: Lever Actuators

Sizes

Mascot cylinder-operated lever actuators can be used to automatically position dampers, louvers, variable pitch fans, and to make other mechanical adjustments to process machinery. Lever actuator designs are available for various sizes of 25, 50 and 100 cylinders

Table XI: Lever Actuator Force

Cyl. Size	Lever Travel		Available Force (lb / N) at Supply Pressure (Psig / Barg)						
	in	mm	80	5.5	100	6.9	150	10.3	
25	4	102	621	2762	776	3452	1164	5178	
	5	127	496	2206	621	2762	932	4146	
	6	152	414	1842	518	2304	776	3452	
	7	178	355	1579	444	1975	665	2958	
	8	203	311	1383	388	1726	582	2589	
	9	229	276	1228	345	1535	518	2304	
	10	254	248	1103	311	1383	466	2073	
	11	279	226	1005	282	1254	423	1882	
	12	305	207	921	259	1152	388	1726	
	50	6	152	1311	5832	1639	7291	2458	10934
		7	178	1124	5000	1405	6250	2107	9372
		8	203	983	4373	1229	5467	1844	8203
9		229	874	3888	1093	4862	1639	7291	
10		254	787	3501	983	4373	1475	6561	
11		279	715	3180	894	3977	1341	5965	
100	12	305	656	2918	819	3643	1229	5467	
	12	305	1428	6352	1852	8238	2913	12958	
	16	406	1071	4764	1389	6179	2184	9715	
	20	508	857	3812	1111	4942	1747	7771	
	24	610	714	3176	926	4119	1457	6481	

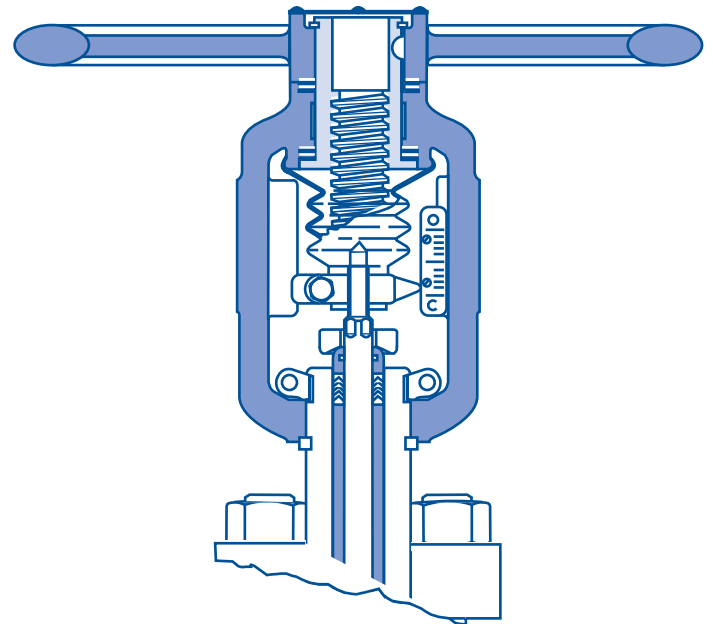

Figure 19: Manual Handwheels

Whenever a very high degree of performance in manual operation is required, manual handwheels are available. Handwheels are of rising stem design and are sized for easy operation. The handwheel yoke is designed to be interchangeable with cylinder or diaphragm actuators.

Table XII: Manual Handwheel Specifications

Hand wheel Size*	Body Size (Class 150-600) inches	Handwheel Diameter inches (mm)		Thrust @50 lb (222N) Rim Pull	
25	1/2 - 2	9 (STD)	230	2024	9003
		12 (OPT)	305	2699	12008
50	3 - 4	12 (STD)	305	2187	9728
		18 (OPT)	455	3280	14590
100	6 (300 & 600) thru 8	18 (STD)	455	2180	9697
		24 (OPT)	610	2907	12931

* Handwheel size is comparable to standard cylinder actuator size.

Linear Actuator

Accessories



Figure 20: Position Transmitter



Figure 21: Limit Switches



Figure 22: Flow Boosters

Accessories

PT is a position transmitter that exceeds the capabilities of normal limit switches by providing a continuous, electrical output signal in proportion to the position of a control valve. PT operates with two wires on a 4 to 20 mA DC voltage, ensuring infinite resolution for safe, dependable monitoring of a control valve's position within linearity ± 1 percent. Mounted on the actuator, the infinite resolution potentiometer is easily adjusted with zero and span settings for field calibration. PT models may contain a potentiometer and transmitter, two or four limit switches, weather and explosion proof protection from external conditions is provided by a rugged aluminum housing.

To electrically indicate open, closed, or intermediate positions of the valve stroke, limit switches can be mounted conveniently. Each switch is firmly mounted on the yoke, with the switch arm contacting an ear on the stem clamp to sense valve position. Single pole or double pole, double-throw switches are available in explosion-proof, hermetically sealed, or weatherproof housings.

To provide fast stroking action with large input signal changes, flow boosters are used on throttling, control valves. At the same time the flow boosters allow normal positioner air flow (and normal actuation) with small changes in the positioner input signal. Boosters can decrease valve stroking times by as much as 90 percent depending on actuator size, packing set and the number used.

Three-way solenoids are used to interrupt an instrument signal to a pneumatic positioner or to operate a spring diaphragm valve.

Four-way solenoids are used on spring cylinder actuators for on-off operation only, insuring fast, positive, two-directional action. Available in a wide variety of operation voltages for both AC and DC, solenoids are standard equipment with a class F coil for continuous duty at temperatures up to 155 degree F (68 degree C). For higher temperature service, optional class H coils are available.

We recommend air filters to the upstream of the positioner which can handle 150 psi (10.3 bar) supply air pressure and features high flow capacity. Easy access to the large drip well permits inspection and replacement of the filter cartridge, while the integral drain valve allows removal of trapped oil, moisture and other foreign material. Regulators are usually not required with Mascot actuators and positioners.

Linear Actuator

Cylinder Systems

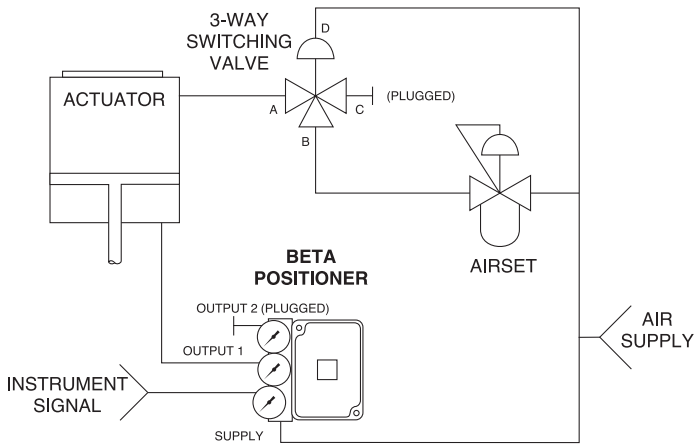

Figure 23:
Air Spring Using Cylinder Volume

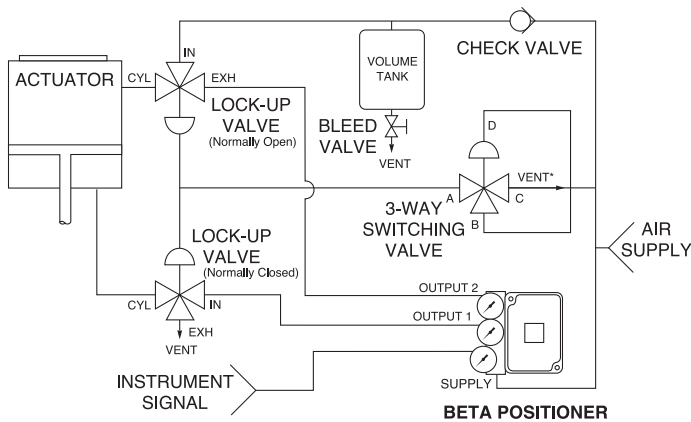

Figure 24:
Air Spring With External Volume Tank

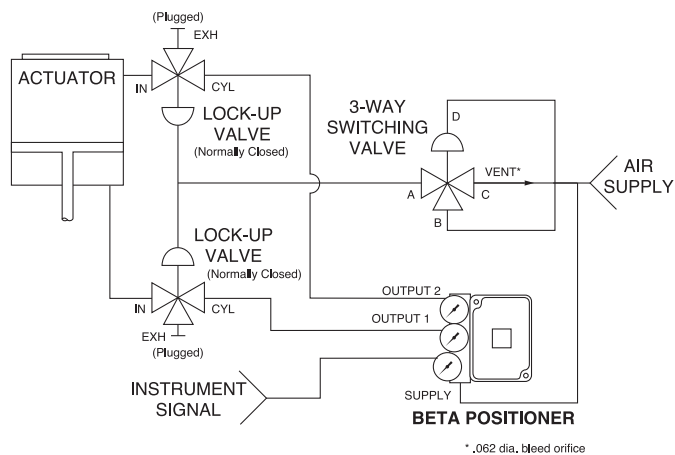

Figure 25: Fail-in-place Lock-up System

Occasionally, few applications call for greater actuator spring forces which standard or dual springs can provide. The air spring is designed to solve many problems where building special, extra-strong failure springs may be mechanically difficult and economically not feasible.

Air springs, which provide a locked-up volume of air to drive the actuator in the failure direction, are used primarily to close valves upon air failure. A fail-closed Mascot valve is customarily operated with the flow directed over the plug. Thus, with the plug on the seat, the upstream pressure acts to hold the valve closed. Air springs on Mascot valves work only during the instant of air failure to drive the valve to the closed position. Process line pressure will insure the valve stays closed.

Air Spring Using Cylinder Volume

Utilizing the stored volume within the cylinder for failure protection, an air spring is a common fail-safe system. In this case, the valve positioner is operated as a 3-way valve positioner to supply air only to the underside of the piston. A 3-way switching valve senses air supply pressure. When pressure drops to a predetermined value, the switching valve locks the air on the upper side of the piston to drive the valve closed. With full air supply pressure to the 3-way switching valve, an airset regulates the proper amount of air pressure to the upper side of the cylinder.

Air Spring with External Volume Tank

If the volume on the top of the cylinder is insufficient to cause the valve to fully stroke upon air failure, an external volume tank is used to supply the additional volume required. This system requires a small lock-up valve in the air supply to each side of the cylinder. The lock-up valve serving the bottom of the piston operates to exhaust that side upon failure. The lock-up valve on the top side of the cylinder admits volume tank air to the cylinder upon air failure. The volume tank can be sized as required.

Fail-in-place Lock-up System

The purpose of this system is to hold the actuator in the last operating position upon air failure. A 3-way switching valve is used to sense air supply. Upon failure of the air supply, this valve operates to exhaust the signal connections to two lock-up valves. These lockup valves, in turn, hold the existing pressure on both sides of the piston, thus locking it in place.

Linear Actuator

Overall dimensions

Table XIII: Standard Actuator and Handwheel (inches/mm)

Cylinder Size (sq. in.)	Body Size (Inches)		Spud Diameter		G*						J	K	L	M***	N					
	Class 125 - 600	Class 900 - 2630			Top-mounted Handwheel															
					Std	Cont. Conn.	Push Only													
25	1/2 to 2	1/2 to 1	2.0	51	14.5	36E	-	-	17.8	454	8.5	155	7.3	186	4.9	124	9.0	229	-	-
50	1/2 to 2	1/2 to 1	2.0	61	18.5	36E	-	-	26.6	678	9.1	232	8.6	218	4.6	118	12.0	305	-	-
	3 to 4, 6 (Class 150)	1 1/2 to 2	2.6	67	20.7	52E	-	-	28.9	733	9.1	232	7.3	184	4.6	118	12.0	305	-	-
100	3 to 4, 6 (Class 150)	1 1/2 to 2	2.6 - 2.9	67 - 73	25.9	65E	44.6	1132	38.1	967	12.5	318	9.9	252	4.5	114	16.0	457	16.0	406
	8 to 14, 10 to 12 (Class 150)	3 to 4	3.4	86	25.9	683	45.6	1157	39.1	992	12.5	318	10.3	280	4.5	114	16.0	457	16.0	406
	10 to 14	6 and larger	4.0 - 4.8	102 - 121	25.9	683	45.6	1157	39.1	992	12.5	318	10.7	272	4.5	114	16.0	457	16.0	406
200	3 to 4, 6 (Class 150)	1 1/2 to 2	2.6 - 2.9	67 - 73	25.6	675	45.2	1149	38.1	967	17.5	445	9.9	252	4.5	114	16.0	457	16.0	406
	8 to 14, 10 to 12 (Class 150)	3 to 4	3.4	86	27.5	699	46.2	1176	39.1	992	17.5	445	10.3	280	4.5	114	16.0	457	16.0	406
	10 to 14	6 and larger	4.0 - 4.8	102 - 121	27.5	699	46.2	1176	39.1	992	17.5	445	10.7	272	4.5	114	16.0	457	16.0	406
300	6 and larger	6 and larger	3.4 - 4.8	86 - 121	31.5	774	54.1	1375	****	****	21.8	532	11.1	283	4.1	105	16.0	457	16.0	406
400	6 and larger	6 and larger	3.4 - 4.8	86 - 121	35.0	930	55.7	1436	****	****	21.8	532	10.7	272	4.5	114	16.0	457	16.0	406
500	6 and larger	6 and larger	3.4 - 4.8	86 - 121	31.0	787	****	****	****	****	28.0	711	11.1	283	4.1	105	16.0	457	16.0	406
600	6 and larger	6 and larger	3.4 - 4.8	86 - 121	45.8	1183	****	****	****	****	21.8	532	11.1	280	4.1	105	16.0	457	16.0	406

* 100 sq. in. and larger, 4-inch maximum stroke. Consult factory.

*** Standard size shown. Handwheel diameter subject to change per torque requirements.
**** Consult factory.

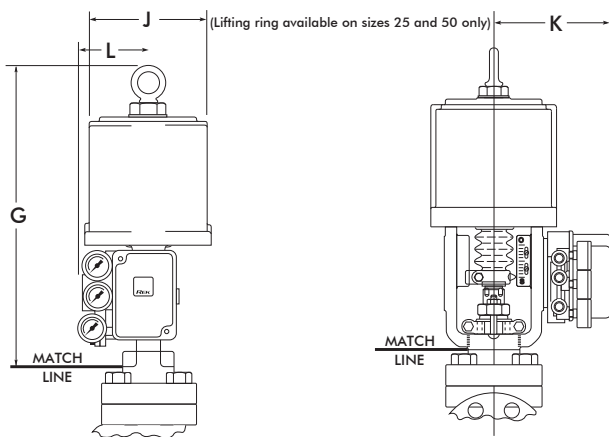

Standard Cylinder Actuator

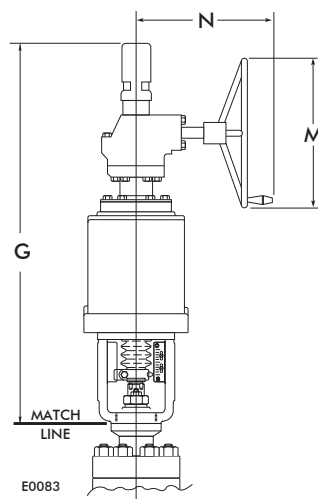

With Top-mounted Continuously Connected Handwheel

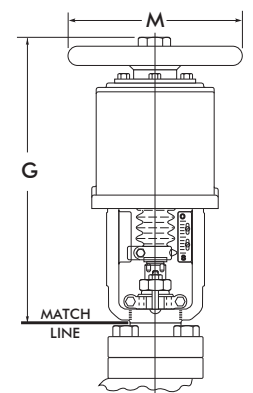

With Push-only Handwheel

Linear Actuator

Overall dimensions

Table XIV: Side-mounted Handwheel Dimensions (Inches/mm)

Cylinder Size	Body Size (inches)		Spud Diameter		Handwheel Design	G*		K		M		N		R	
	Class 150-600	Class 900-2500													
25	1/2 to 2	1/2 to 1	2.0	51	Acme Screw	17.9	454	7.3	186	9.0	229	9.4	238	7.3	185
	1/2 to 2	1/2 to 1	2.0	51	Acme Screw	21.9	555	7.8	199	9.0	229	9.4	238	7.3	185
50	3 to 4, 6 (Class 150)	1 1/2 to 2	2.6	67	Acme Screw	25.6	650	7.3	184	12.0	305	12.7	322	10.3	262
	3 to 4, 6 (Class 150)	1 1/2 to 2	2.6	67	Acme Screw	28.9	735	8.6	218	12.0	305	12.7	322	10.3	262
	4, 6 (Class 150)		2.9	73	Bevel Gear	40.9	1038	9.9	252	18.0	457	15.3	388	13.8	352
100	6 to 8, 10 to 12 (Class 150)	3 and 4	3.4	86	Bevel Gear	41.8	1062	10.3	260	18.0	457	15.3	388	14.8	376
	10 to 14	6 and larger	4.0-4.8	102-121	Bevel Gear	41.8	1062	10.7	272	18.0	457	15.3	388	14.8	376
	4, 6 (Class 150)		2.9	73	Bevel Gear	41.6	1057	9.9	252	18.0	457	15.3	388	13.8	352
200	6 to 8, 10 to 12 (Class 150)	3 and 4	3.4	86	Bevel Gear	42.6	1082	10.3	260	18.0	457	15.3	388	14.8	376
	10 to 14	6 and larger	4.0-4.8	102-121	Bevel Gear	42.6	1082	10.7	272	18.0	457	15.3	388	14.8	376

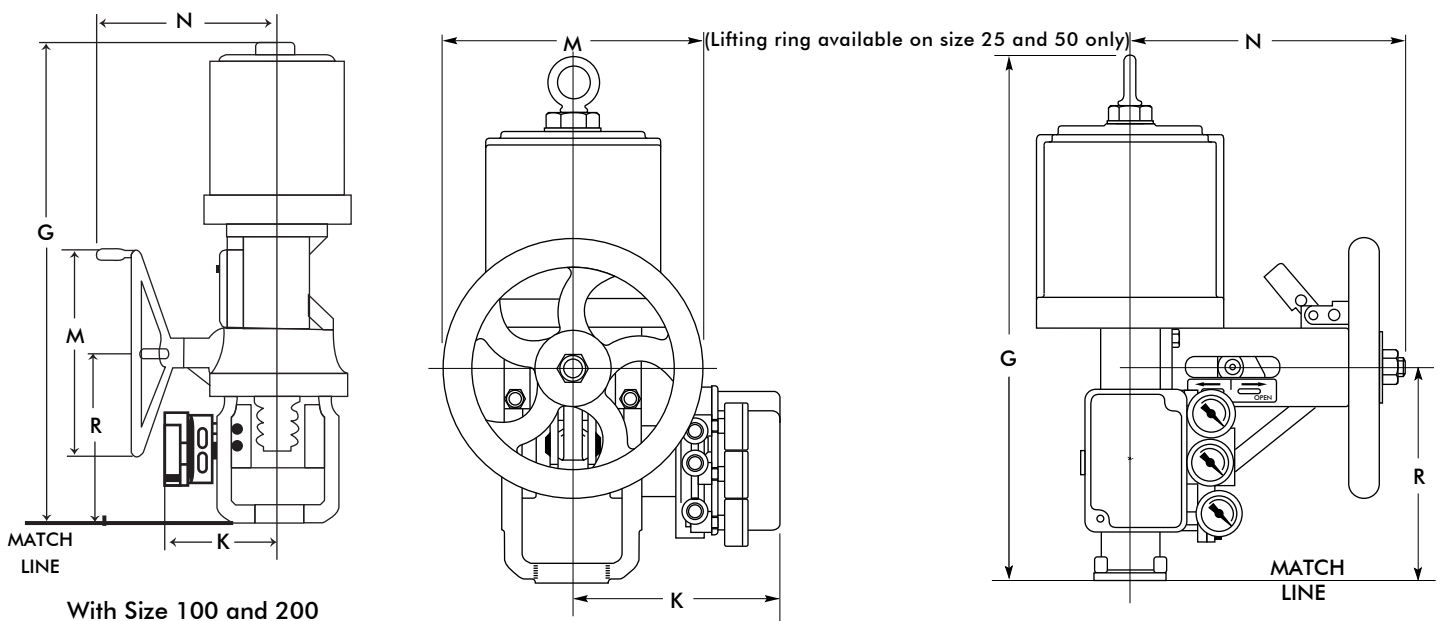

Linear Actuator

Overall dimensions

Table XV: Manual Handwheel Dimensions (inches/mm)

Handwheel Type	Body Size (inches) Class 150 to 600	Spud Size (inches)	G		M	
HA	1/2 to 2	2.00	8.8	223	9.0	229
HB	3, 4, 6 (Class 150)	2.62/2.88	13.1	334	12.0	305
			13.3	339	18.0	457
HC	4, 6 (Class 150)	2.88	17.4	442	18.0	457
			18.0	457	24.0	610
HD	6 (Class 300, 600), 8, 10, 12 (Class 150)	3.38	17.5	445	18.0	457
			18.1	461	24.0	610

